

Ultrasonic industrial cleaners - I +



KRAINTEK, s. r. o.



- ultrasonic cleaners are for industrial use, high resistance
- ultrasonic cleaners are made from stainless steel 1.4301
- possibility of production from steel 1.4571
- high efficiency, reliability, dimensional unpretentiousness and safety
- part of cleaner is cover
- emitter's material has thickness 2,5 mm
- working frequency is 25kHz, 30kHz, 35kHz, 40kHz by request
- generator is control by DSP processor for superior cleaning
- PLL phase hinge for autotuning
- constant output, amplitude modulation
- high-performance heating
- thermal protection
- set-up time constant motion / 0 - 99 min.
- setting of temperature 20 - 80 °C
- DEGAS - fast degassing
- SWEEP - sweep of working frequency
- REAL - display of actual parameters
- INTENSITY - ultr. intensity 10 - 100 %
- supply voltage 230V/50Hz ± 10 %
- connecting cable 3 m

Type	Internal dimensions a-b-c-d mm	External dimensions e-f-g-h-i mm	Maximal capacity L	Weight kg	Outlet "	Ultrasonic power W	Heater power W	Frequency kHz *	Piezoceramics elements	Digital control
K-12	315-285-180-160	390-360-400-291-321	16,0	14,0	1/2 "	200	1000	35	6	K-12IE+
K-17	600-150-220-200	675-225-265-331-361	19,8	18,0	1/2 "	400	1000	35	12	K-17IE+
K-25	490-285-210-190	565-360-400-321-351	29,0	20,0	1/2 "	450	1000	35	12	K-25IE+
K-30	530-340-200-180	603-415-455-311-331	36,0	26,0	3/4 "	450	1400	35	12	K-30IE+
K-40	530-340-260-240	603-415-455-371-401	46,0	29,0	3/4 "	600	1400	35	14	K-40IE+
K-50	530-340-315-280	603-415-455-426-456	56,0	32,0	3/4 "	700	1400	35	16	K-50IE+
generator + control unit	220-320-156		-	8,0	-	-	-	-	-	-

* by customer's demand 25 kHz, 30 kHz, 40 kHz

- possibility of production non-standard variants by request of customer

www.kraintek.sk

Ultrazvukové priemyselné čističky - I +



KRAINTEK, s. r. o.

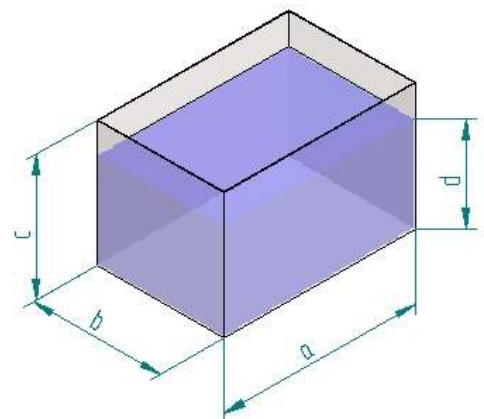
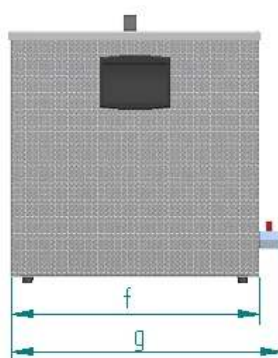
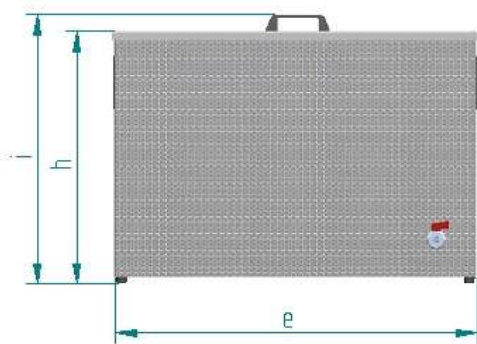

www.kraintek.sk